

INSTRUCTION MANUAL FOR

STEREO TRIGGERSCOPE

MODEL 5501A

KIKUSUI ELECTRONICS CORPORATION

1, 2, 3, 8, 12, 16, 17, 24, 25, 27.

28, 8, 14

782101

# Power Requirements of this Product

Power requirements of this product have been changed and the relevant sections of the Operation Manual should be revised accordingly.

(Revision should be applied to items indicated by a check mark )

Input voltage

The input voltage of this product is \_\_\_\_\_ VAC,  
and the voltage range is \_\_\_\_\_ to \_\_\_\_\_ VAC. Use the product within this range only.

Input fuse

The rating of this product's input fuse is \_\_\_\_\_ A, \_\_\_\_\_ VAC, and \_\_\_\_\_.

## WARNING

- To avoid electrical shock, always disconnect the AC power cable or turn off the switch on the switchboard before attempting to check or replace the fuse.
- Use a fuse element having a shape, rating, and characteristics suitable for this product. The use of a fuse with a different rating or one that short circuits the fuse holder may result in fire, electric shock, or irreparable damage.

AC power cable

The product is provided with AC power cables described below. If the cable has no power plug, attach a power plug or crimp-style terminals to the cable in accordance with the wire colors specified in the drawing.

## WARNING

- The attachment of a power plug or crimp-style terminals must be carried out by qualified personnel.

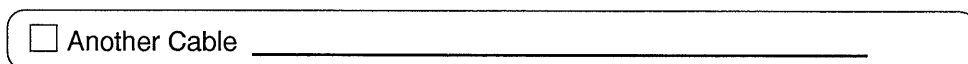
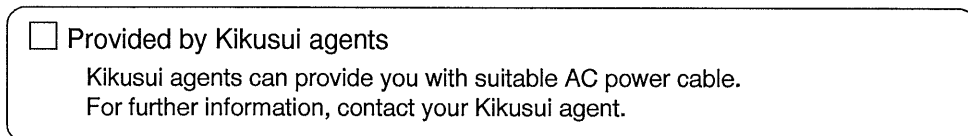
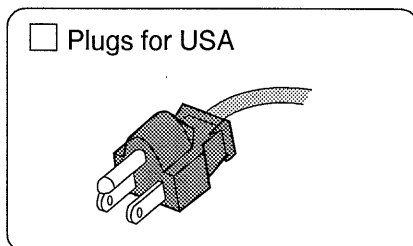
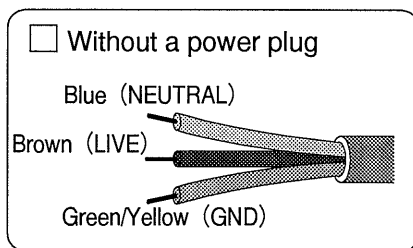

TABLE OF CONTENTS

	<u>PAGE</u>
1. DESCRIPTION AND SPECIFICATION .....	1
1-1. GENERAL .....	1
1-2. FEATURES .....	1
1-3. CONSTRUCTION .....	4
1-4. SPECIFICATION .....	5
2. OPERATING PROCEDURE .....	13
2-1. EXPLANATION OF FRONT PANEL .....	13
2-2. EXPLANATION OF REAR PANEL .....	20
2-3. EXPLANATION OF LEFT AND RIGHT PANELS .....	20
2-4. OPERATION AND MEASUREMENT .....	22
2-5. PRECAUTIONS IN OPERATION .....	26
2-6. AC LINE VOLTAGE MODIFICATION .....	27
3. APPLICATION EXAMPLES .....	28
3-1. VOLTAGE MEASUREMENT .....	28
3-2. FREQUENCY MEASUREMENT .....	30
3-3. PHASE MEASUREMENT .....	33
4. MAINTENANCE AND ADJUSTMENT .....	38
4-1. MAINTENANCE .....	38
4-2. ADJUSTMENT .....	40
SCHEMATIC DIAGRAMS .....	51

789100

## 1. DESCRIPTION AND SPECIFICATION

### 1-1. GENERAL

Model 5501A Stereo Triggerscope is a triggered-type horizontal-dual-channel oscilloscope with vertical amplifiers of frequency bandwidth 1.5 MHz and sensitivity 10 mV/DIV or over and with horizontal amplifiers of sweep frequency range of 10 Hz - 100 kHz (in four sub-ranges). IC's are fully employed in the vertical amplifiers, trigger circuit and horizontal sweep circuit, thereby suppressing DC drifts to a very small level and realizing very simple but stable comparison between right and left channels. The 5501A Triggerscope is very easy to operate since triggering is positively effected with even a very low level signal. Since this oscilloscope can be used versatile applications with the alternate trigger function and CHL + CHR(ADD) trigger function when in the stereo mode operation. The 5501A Triggerscope employs a high-intensity CRT which provides a bright trace which can be easily observed. Further, the triggerscope is compact (170 mm wide, 260 mm high), providing a good space factor.

### 1-2. FEATURES

#### o Triggered sweep system:

The 5501A employs a triggered sweep system, ensuring positive sweep synchronization regardless of the input signal frequency. When operated in the AUTO trigger mode, the instrument displays the base line even when no input signal is being applied, providing a simple means for ZERO level check.

#### o Highly stable vertical amplifiers:

Since the vertical amplifiers fully employ IC's, their DC drifts are very small and they provide a frequency range of DC - 1.5 MHz for -3 dB and the maximum sensitivity of 10 mV/DIV or over.

- o Wide AUTO trigger frequency range:

The AUTO trigger frequency range is as wide as 10 Hz - 1.5 MHz. Triggering is positively effected at frequencies higher than 10 Hz, ensuring reliable observation of phases and amplitudes at low frequencies.

- o Either horizontal or vertical dual-channel display:

The instrument normally is operated in a horizontal dual-channel mode. It also can be operated in a vertical dual-channel mode by selecting it with the DISPLAY MODE switch.

- o Stable dual-channel triggering:

With a conventional oscilloscope, stable patterns cannot be displayed unless there is a synchronizing relationship or an integer ratio between two input signals (CHL and CHR).

With the 5501A that employs alternate trigger function and CHL + CHR (ADD) trigger function, stable patterns are displayed with perfect synchronization even when the two signals are mutually independent without any synchronizing relationship, except when triggering is in the only CHL mode or EXT mode.

- o Sweep directions from both ends to the center:

The sweeps run from the right and left ends to the center of CRT. This feature enables accurate phase measurement.

- o Sweep length selector switch "x2":

As you depresses the x 2 switch when the MODE switch is turned from the STEREO state to the CHL or CHR state, the sweep length is magnified by a factor of 2 so that the pattern is displayed on the full span on the CRT screen.

789104

- o X-Y operation:

When the SWEEP RANGE switch is set in the X-Y position, the 5501A operates as a X-Y scope with CHL as X and CHR as Y. This mode is used for phase measurement or frequency measurement with a Lissajous figure.

- o Accurate and reliable calibration voltage:

The 5501A provides a calibration voltage signal of 50 mVp-p +5%, approximately 1 kHz. Voltage calibration of CHL and CHR can be accomplished in a simple method: Just connect the CAL VOLT OUTPUT terminal (jack) to the INPUT terminal of each channel with the input cord (BAW-1, supplied) and adjust the VAR knob as required.

- o High intensity CRT:

The high intensity CRT displays a bright trace, making the trace discernible even at high sweep speeds.

- o Stable acceleration voltage:

The acceleration voltage is stabilized, making the displayed pattern unaffected by line voltage variation or trace intensity change.

1-3. COMPOSITION

A complete set of the instrument is composed of the following items:

Triggerscope main unit ..... 1

Accessories

Input cords (BAW-1) ..... 2

Instruction manual ..... 1

1-4. SPECIFICATION

o Vertical Deflection Circuit

Item	Specification	Remarks
Sensitivity	10 mV/DIV or over	1 DIV = approx. 9.5 mm
Attenuator	1/1, 1/10, 1/100, with $\pm 3\%$	4 ranges including GND
Sensitivity adjustment	Covers between ranges with continuously-variable adjustment	Adjustable range: 10 times or over.
Frequency response	DC: DC ~ 1.5 MHz, within -3 dB AC: 2 Hz ~ 1.5 MHz, within -3 dB	With 50 kHz, 8 DIV as reference.
Input impedance	1 M $\Omega$ $\pm 2\%$ , 50 pF or less	Parallel
Input terminals	Binding posts	
Maximum allowable input voltage	400 Vp-p for all ranges	DC + AC peak. (AC frequency not higher than 1 kHz)
Rise time	Approx. 230 nsec	Calculated value
Isolation of between channels	500 : 1 or better	100 kHz, 8 DIV



Item	Specification		Remarks	
Mode	CHL	Channel L alone		
	CHR	Channel R alone		
	STEREO	Alternate sweeps between channels L and R		At ranges other than X-Y
		Switched between channels L and R at approx. 30 kHz		When range is 10 Hz ~ 100 Hz and triggering is CHL
Display mode	H	Horizontal dual-channel display		
	V	Vertical dual channel display	Distance between L and R channel base lines is fixed at approx. 4 DIV.	
Linearity	When a signal displayed for 4 DIV in CRT screen center is vertically shifted for the full screen range, vertical amplitude change is within $\pm 0.2$ DIV.		At frequency not higher than 100 kHz. Including linearity of CRT.	

o Horizontal Deflection Circuit

Item	Specification	Remarks
Sweep frequency	10 Hz ~ 100 Hz 100 Hz ~ 1 kHz 1 kHz ~ 10 kHz 10 kHz ~ 100 kHz	5 ranges including X-Y range
Frequency adjustment	Covers between ranges with continuously- variable adjustment.	Adjustable range: 10 times or over
Sweep linearity	$\pm 5\%$ or better	
Sweep length magnification	Approx. 2 times	

782109

o Trigger

Item	Specification		Remarks
Trigger signal source	NORM (ALT)	Triggered with CHL and CHR signals.	
	CHL	Triggered with CHL signal alone.	
	CHL + CHR	Triggered with the sum of the signals of CHL and CHR.	CHL and CHR signals must be of the same frequency.
	EXT	Triggered with external signal.	
Sensitivity	INT	10 Hz - 50 Hz, 2 DIV or over 50 Hz - 1.5 MHz, 1 DIV or over	In terms of displayed signal amplitude on the CRT.
	EXT	10 Hz - 50 Hz, 1 Vp-p or over 50 Hz - 1.5 MHz, 0.5 Vp-p or over	
Trigger system	AUTO trigger sweep		When no signal is applied, the sweep occurs in FREE RUN mode. For input signal of 10 Hz or higher, the above trigger sensitivity specification is met.
External trigger input impedance	Approx. 220 k $\Omega$ , 50 pF or less		Parallel
External trigger input terminal	Panel Jack		

Item	Specification	Remarks
Maximum allowable external input voltage	100 V <sub>p-p</sub>	DC + AC peak (AC frequency not higher than 1 kHz)

o External Sweep Amplifier (X-Y)

Item	Specification	Remarks
System	X-Y system, CHL for X and CHR for Y.	X = horizontal axis, Y = vertical axis
Sensitivity	X: 10 mV/DIV or over Y: 10 mV/DIV or over	1 DIV = approx. 9.5 mm
Frequency response	X: DC ~ 500 kHz, within -3 dB	With reference to 50 kHz, 10 DIV
	Y: DC ~ 1.5 MHz, within -3 dB	With reference to 50 kHz, 8 DIV
Input impedance	1 MΩ ±2%, 50 pF or less (for both X and Y)	Parallel
Maximum allowable input voltage	400 V <sub>p-p</sub> , for all ranges, for both X and Y	DC + AC peak (AC frequency not higher than 1 kHz)
Input terminals	Binding posts, for both X and Y	
Phase accuracy	Within 3° at 20 kHz	

o Calibration Voltage

Item	Specification	Remarks
Waveform	Square wave	
Polarity	Positive	
Output voltage	50 mVp-p	
Output voltage accuracy	±5% or better	
Frequency	1 kHz ±25%	
Duty ratio	40 : 60 ~ 50 : 50	
Rise time	Approx. 500 nsec or faster	
Output terminal	Panel jack	

o CRT

Item	Specification	Remarks
Type	133-mm round cathode ray tube	High-intensity type
Fluorescent substance	B31	
Acceleration voltage	Approx. 1500 V	Stabilized
Effective screen area	8 × 10 DIV	1 DIV = approx. 9.5 mm
Blanking	With G1	

782112

o Power Requirements

Item	Specification	Remarks
AC line voltage	100, 110, 117, 220, 230, 240 V, within $\pm 10\%$	Selectable with transformer taps. (Normally is connected to the 100 V tap when instrument is shipped from manufacturer's factory.)
Frequency	50 ~ 60 Hz	
Power consumption	Approx. 20 VA	

o Mechanical Specification

Item	Specification	Remarks
External dimensions	165 W $\times$ 240 H $\times$ 405 D mm	External dimensions of casing
	170 W $\times$ 260 H $\times$ 455 D mm	Maximum dimensions
Weight	Approx. 7.0 kg	

# FRONT PANEL OF TRIGGERSCOPE

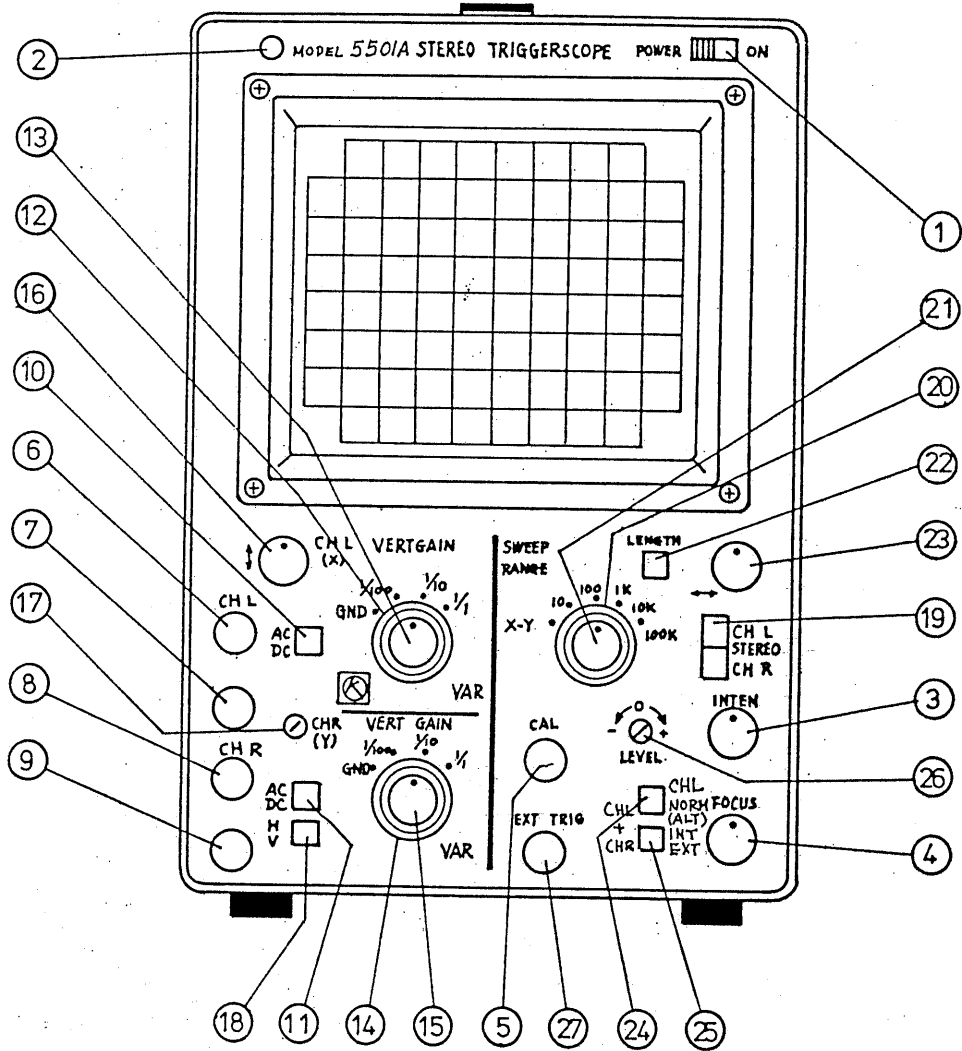

## 2. OPERATING PROCEDURE

### 2-1. EXPLANATION OF FRONT PANEL

① POWER:

The slide switch for ON-OFF control of instrument power. Right-hand position is for ON.

② LED:

The LED (light emitting diode) which lights when the POWER switch is turned ON.

③ INTEN:

CRT trace intensity control knob. With clockwise turning, the trace becomes brighter; with counterclockwise turning, the trace becomes less bright and it disappears as the knob is turned to the extremely counterclockwise position.

④ FOCUS:

For focus control of displayed trace. So adjust this knob that the trace image becomes sharpest.

⑤ CAL 50 mVp-p:

This terminal provides the reference square-wave signal for sensitivity calibration when in CHL, CHR or X-Y operation mode. The calibration signal is 50 mVp-p, approx. 1 kHz.

⑥ CHL:

Vertical signal input terminal for CHL.

⑦ GND:

GND terminal for CHL.



⑧ CHR:

Vertical signal input terminal for CHR.

⑨ GND:

GND terminal for CHR.

⑩ AC , DC  :

Pushbutton switch for selection of coupling mode of CHL vertical input. The popped up state is for AC and the depressed state for DC. With the AC coupling, DC components are cut off and AC components alone are observed; with the DC coupling, all components including DC are observed.

⑪ AC , DC  :

Pushbutton switch for selection of coupling mode of CHR vertical input. Its function is the same with that of switch ⑩.

⑫ CHL (X) VERT GAIN:

Vertical gain range selector of CHL for 1/1, 1/10, and 1/100. Select a range suitable for the input voltage. When set in the GND position, the input terminals are made open and the input circuit of the internal vertical amplifier is grounded.

⑬ VAR:

Gain adjustment of CHL. Gain is continuously variable between two ranges of CHL (X) VERT GAIN ⑫.

⑭ CHR (Y) VERT GAIN:

Vertical gain range selector of CHR. Its function is the same with that of the CHL (X) VERT GAIN selector switch of ⑫.

782116

⑮ VAR:

Gain adjustment of CHR. Gain is continuously variable between two ranges of CHR (Y) VERT GAIN selector switch ⑭.

⑯  $\updownarrow$  :

Vertical positioning knob. The displayed trace moves upward as this knob is turned clockwise, and vice versa.

⑰ POSI BAL  $\Delta$  :

Position balancing of CHL and CHR base lines. The CHR base line alone is moved vertically so that it is aligned with the CHL base line.

⑱ DISPLAY MODE H  $\square$ , V  $\square$  :

Pushbutton switch for selection the deflecting direction (vertical or horizontal) of the CHL and CHR input signals. The popped up state is for horizontal deflection and the depressed state for vertical deflection. When the SWEEP RANGE switch ⑳ is set in the X-Y position, the DISPLAY MODE switch normally is set in the H  $\square$  position.

⑲ MODE:

Pushbutton switches for sweep mode selection. When CHL button is depressed, sweep is effected for CHL alone; when CHR button is depressed, sweep is effected for CHR alone. When both buttons are depressed or are in the popped up state (STEREO mode), CHL and CHR are swept alternately. If the SWEEP RANGE switch ⑳ is set in the 10 ~ 100 range and the TRIGGER MODE switch ㉔ is in the CHL  $\square$  state, the sweep is switched at a frequency of approximately 30 kHz.

782117

⑳ SWEEP RANGE (Hz):

Horizontal sweep frequency selector switch for five ranges of "10 - 100", "100 - 1k", "1k - 10k", "10k - 100k", and "X-Y". The sweep frequency is in terms of the input signal frequency which provides one cycle of signal displayed on the CRT screen when the instrument is operated in the single-channel mode (with the LENGTH switch ㉒ not depressed). For the "X-Y" mode of operation, CHL is X and CHR is Y.

㉑ VAR:

Continuously-variable sweep frequency adjustment between two ranges of SWEEP RANGE switch ㉒. Sweep frequency increases as this knob is turned clockwise, and vice versa. When SWEEP RANGE switch ㉒ is set in the "X-Y" position, this knob remains idle.

㉒ LENGTH PUSH ×2:

The sweep length is magnified by about twice as this pushbutton switch is depressed when the MODE switch ㉑ is set in the CHL or CHR position or when it is set in the STEREO position and the MODE switch ㉑ is set in the V<sub>u</sub> state.

(Note: When this switch is depressed, the sweep frequency is approximately 5 Hz to approximately 50 kHz.)

㉓ ↔ :

Horizontal positioning knob. The trace moves rightward as this knob is turned clockwise, and vice versa.

㉔ CHL ■, NORM ■ (TRIG):  
(ALT)

Pushbutton switch for trigger mode selection when INT/EXT switch ㉕ is set in the INT ■ state. When in the CHL ■ state, the sweep is triggered by the CHL input signal; when in the NORM ■ state, the sweeps are triggered by the CHL and CHR input signals, respectively. Thus, when in the NORM ■ state, the sweeps are synchronized even if the frequencies of the two input signals of CHL and CHR are mutually different or even if one of the two signals has become zero.

②⑤ INT  , EXT  (TRIG):

Input selector switch of trigger amplifier. When in the INT  state, the CHL or CHR signal is connected to the trigger amplifier; when this switch is set in the EXT  state and switch ②④ in the CHL  state, the signal supplied to the EXT TRIG IN terminal ②⑦ is connected to the trigger amplifier.

②④ , ②⑤ EXT  , NORM (ALT)  (TRIG):

When both switches ②④ and ②⑤ are set in the depressed state, the sweep circuit is triggered with the sum of the signals of CHL and CHR. In this case, therefore, the signals applied to CHL and CHR must be of the same frequency.

Further, the phase difference between the two signals must be a sphere excludeing approximately  $180^{\circ}$ .

When one of the two signals of CHL and CHR has become zero, the circuit is triggered by the signal of the other channel.

If the signals applied to the CHL and CHR are different, the switch must be set in the NORM (ALT) state. Note that in this case the displayed waveform is not synchronized if one of the two input signals is zero.

②⑥ LEVEL (TRIG):

For adjustment of the triggering level (a point on the trigger signal waveform slope) at which the sweep starts. The level becomes higher as this knob is turned clockwise, and vice versa.

②⑦ EXT TRIG IN:

When the INT/EXT switch ②⑤ is set in the EXT  state and switch ②④ is set in the CHL  state, the signal connected to this terminal is to the trigger amplifier and the sweep is triggered being synchronized with this signal.

REAR PANEL OF TRIGGERSCOPE

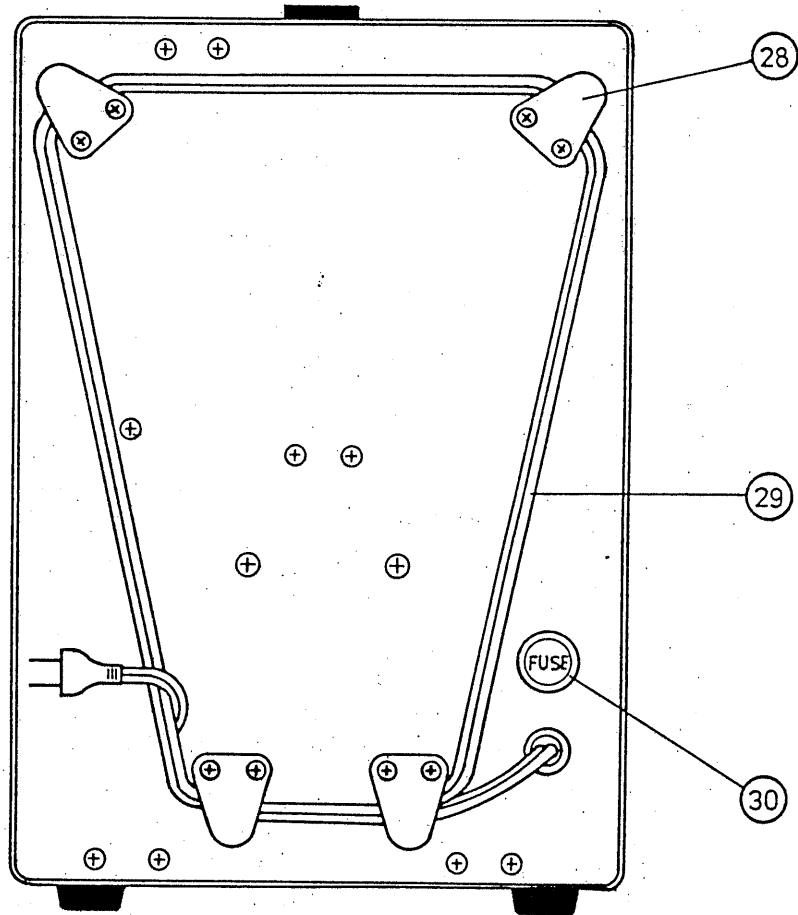

782120

LEFT PANEL AND RIGHT PANEL OF TRIGGERSCOPE

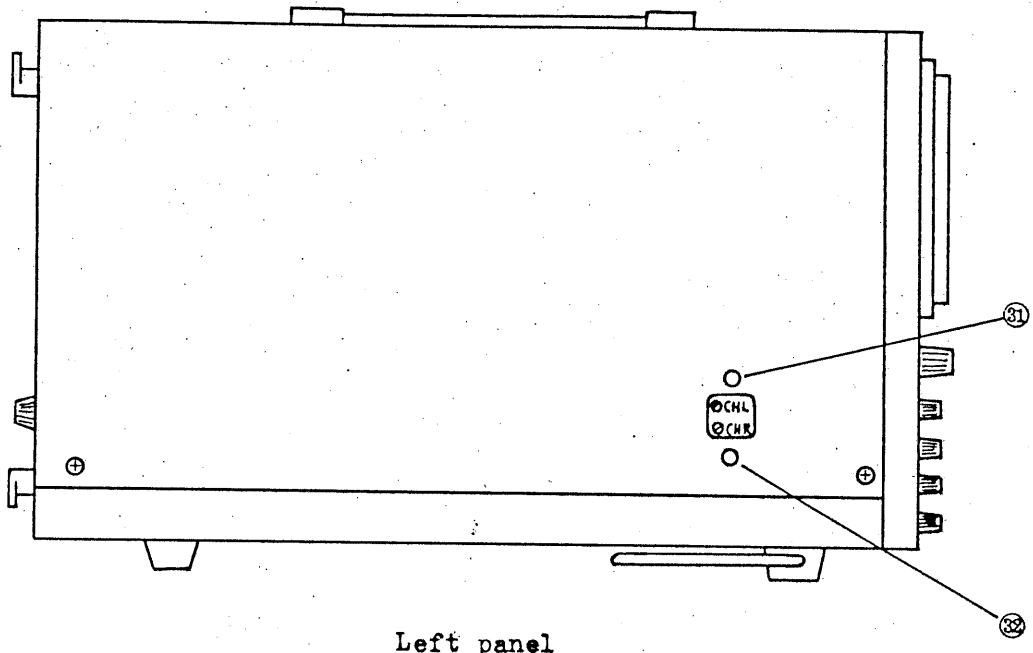

Left panel

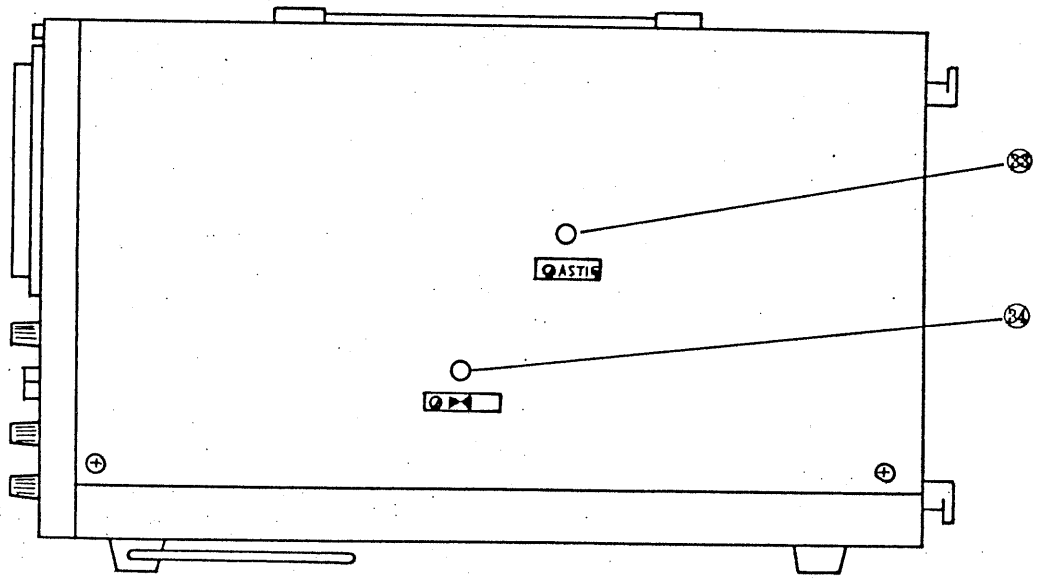

Right panel

782121

2-2. EXPLANATION OF REAR PANEL

②8 Cord holder:

Holds the power cord when the instrument is carried or stored. Also serves as studs when the instrument is used in a standing attitude.

②9 Power cord:

AC power cord of the instrument.

③0 Fuse holder:

AC power line fuse holder (0.5-ampere fuse).

2-3. EXPLANATION OF LEFT AND RIGHT PANELS

③1 CHL DC BAL:

Vertical DC balance control for CHL. So adjust this control that the trace does not vertically shift when the VAR knob ①3 of CHL is turned.

③2 CHR DC BAL:

Vertical DC balance control for CHR. So adjust this control that the trace does not vertically shift when the VAR knob ①5 of CHR is turned.

782122

③③ ASTIG:

Astigmatism control. So adjust this control, in conjunction with the FOCUS knob ④, that the beam spot becomes sharpest.

③④ ▶◀ ADJ:

For separation adjustment of the horizontal traces of CHL and CHR. The two traces move mutually apart as this control is turned counterclockwise; they move mutually nearer and overlap ultimately as this control is turned clockwise.



2-4. OPERATION AND MEASUREMENT

Before connecting the power cord to an AC line outlet, set the switches and controls on the front panel as indicated in the following table.

Switch or control	Setting
① POWER	POWER OFF
③ INTEN	Slightly rightward from center
④ FOCUS	Center
⑩ AC <input type="checkbox"/> , DC <input type="checkbox"/>	AC <input type="checkbox"/>
⑪ AC <input type="checkbox"/> , DC <input type="checkbox"/>	AC <input type="checkbox"/>
⑫ CHL VERT GAIN	GND
⑬ VAR	Extremely clockwise position
⑭ CHR VERT GAIN	GND
⑮ VAR	Extremely clockwise position
⑯ $\updownarrow$	Center
⑰ DISPLAY MODE	H <input type="checkbox"/>
⑱ MODE	STEREO
⑳ SWEEP RANGE (Hz)	100 ~ 1k range
㉑ VAR	Extremely clockwise position
㉒ LENGTH PUSH $\times 2$	Popped up state
㉓ $\leftrightarrow$	Center
㉔ CHL <input type="checkbox"/> , NORM <input type="checkbox"/>	CHL <input type="checkbox"/>
㉕ INT <input type="checkbox"/> , EXT <input type="checkbox"/>	INT <input type="checkbox"/>

782124

o Operating Procedure

Throw the POWER switch (1) to the ON position (rightward position) so that the instrument power is turned on and the POWER lamp (LED) lights. A trace will be displayed on the CRT screen in 10 - 20 seconds. If the trace is not in the screen center, move it to the center by means of the VERTICAL POSITIONING knob  $\updownarrow$  (16). So adjust the INTENSITY control (3) and FOCUS control (4) that the trace is made clear and sharp.

Preparations for measurement are complete by the above procedure.

Apply the signal to be measured to CHL and CHR input terminals (6), (7), (8) and (9). Set the VERT GAIN switches (12) and (14) in the 1/100, 1/10, or 1/1 range position and adjust the VAR knobs (13) and (15) so that waveforms with appropriate amplitudes (approximately 4 DIV) are displayed on the screen. To display the signal of CHL or CHR alone, set the MODE switch (19) in the CHL or CHR position.

For more stable observation of signals with low sweep frequencies, set the SWEEP RANGE switch (20) in the "10 - 100" range position and the TRIGGER MODE switch (24) in the CHL I state in order that the CHL and CHR waveforms and sweep signals are displayed being switched with a frequency of approximately 30 kHz.

To observe waveforms including DC components, set the INPUT coupling AC/DC switches (10) and (11) in the DC m state. The positive signal deflects the trace upward on the screen and the negative signal downward. The zero potential level can be readily known by turning the VERT GAIN switches (12) and (14) to the GND position.

782125

o Measuring Procedure

Single-channel Measurement:

Depress the CHL or CHR button, as required, of MODE switch (19).

Set the DISPLAY MODE switch (18) in the V<sub>LM</sub> state. The sweep will run from the left-hand end to the center.

Move the trace to the vertical center by means of the VERTICAL POSITIONING knob  $\updownarrow$  (16).

Set the INPUT COUPLING AC/DC switch (10) or (11) in the AC state and adjust the displayed waveform to an appropriate amplitude with the VERT GAIN switch (12) or (14) and the VAR control (13) or (15). For observation of a pulse signal or a DC-superimposed signal, set the INPUT COUPLING AC/DC switch (10) or (11) in the DC<sub>LM</sub> state.

Adjust the sweep frequency with the SWEEP RANGE switch (20) and VAR control (21). The number of displayed cycles is numerous as the sweep frequency is lower as compared with the measured signal frequency and it is few as the sweep frequency is higher. With a sweep frequency still higher, only a fraction of one cycle of the measured signal is displayed and, with a very high sweep speed, the trace becomes dim.

Set the TRIGGER MODE switch (24) in the NORM<sub>LM</sub> state and the INT/EXT switch (25) in the INT<sub>LM</sub> state. When the vertical input is CHL, the signal can be observed also by setting the TRIGGER MODE switch (24) in the CHL<sub>LM</sub> state. Note that, if the signal amplitude is less than 1 DIV on the CRT screen, triggering may become unstable and the sweep may be asynchronized with the observed signal.

When no input signal is being applied, a bright trace appears on the screen due to the function of the AUTO TRIGGER circuit.

782126

The above explanation is for the left-hand half of the CRT screen. To display the waveform on the full span of the CRT screen, depress the LENGTH  $\times 2$  switch (22). Note, however, that this mode of operation is feasible for about a half (approx. 5 Hz - 50 kHz) of the maximum sweep frequency range (10 Hz - 100 kHz).

#### Dual-channel Measurement:

Depress at the same time to CHL and CHR buttons of MODE switch (19) to obtain the STEREO mode. If you set the DISPLAY MODE switch (18) in the H    state, the instrument operates in the horizontal dual-channel mode with the two signals displayed right-hand side and left-hand side. If you set the switch (18) in the V    state, the instrument operates in the vertical dual-channel mode with the two signals displayed at top and bottom being apart by about 4 DIV, on the CRT.

When the TRIGGER MODE switch (24) is set in the NORM    state and switch (25) in the INT    state, the sweeps are synchronized even when the frequencies of the two input signals are mutually different.

When the input signals of CHL and CHR are of the same frequency and there is a possibility that one of the two input signal becomes zero, operate in the CHL + CHR ADD trigger mode by depressing both (24) and (25) buttons.

When the TRIGGER MODE switch (24) is set in the CHL    state, the sweep is triggered by the input signal of CHL. When the switch (25) is set in the EXT    state, the switch (24) is set in the CHL    state and an external trigger signal is applied, the sweep is synchronized to a frequency which has an integer ratio relationship with respect to the external trigger signal.

Adjust the sweep speed to an appropriate frequency with the SWEEP RANGE switch (20) and VAR control (21).

782127

When the SWEEP RANGE switch (20) is set at the "10 - 100" range and the TRIGGER MODE switch (24) in the CHL    state, the input signals and sweeps are switched at a frequency of approximately 30 kHz thereby enabling convenient observation at low sweep frequencies.

When the SWEEP RANGE switch (20) is set at the "100 - 1k", "1k - 10k" or "10k - 100k" range or when it is set at the "10 - 100" range and the TRIGGER MODE switch (24) in the NORM    state, the traces of CHL and CHR are swept alternately.

When the TRIGGER MODE switch (24) is set in the NORM    state and the input signal is applied to the CHL or CHR channel alone, no triggering is effected and the sweep is asynchronized. In such a case operate the instrument in the single-channel mode by depressing the CHL or CHR button on the MODE switch (19).

When the TRIGGER MODE switch (24) is set in the NORM    state and the CHL or CHR input signal is lower than the trigger level, triggering becomes ineffective and the sweep is asynchronized. In such a case, make the input signal higher than the trigger level.

## 2-5. PRECAUTIONS IN OPERATION

### o AC line voltage:

Ensure that the AC line voltage setting of the instrument conforms with the voltage of the AC line on which the instrument is to be operated. Note that the instrument may not properly operate or may be damaged if it is operated on an AC line power of incorrect voltage. (The instrument normally is set at 100 V when it is shipped from the factory.) For AC line voltage modification, refer to Sub-section 2-6.

782128

o Ambient temperature:

The instrument operates normally (satisfies its performance specification) at ambient temperature of 0°C ~ 40°C.

o Environmental conditions:

Do not operate or store the instrument in high-temperature high-humidity atmosphere for a long time. Also avoid a place where is subject to strong magnetic field, electric field, radiation field, or mechanical vibration.

o Others:

When operating the instrument in the X-Y mode, do not leave the beam spot stationary for a long period of time lest the fluorescent screen of the CRT should be damaged (burnt).

## 2-6. AC LINE VOLTAGE MODIFICATION

The instrument is shipped from the factory being set for 100V AC line power use. To operate the instrument on other AC line voltage, change the taps of the power transformer as required. Since the plug of the AC power cord is 125V-6A rating, replace it with a plug of 250V rating when the instrument is to be used on an AC line voltage higher than 125 V. Use a fuse as indicated in the following table.

AC line voltage (V)	Fuse (A)
100 ( 90 ~ 110) 110 ( 99 ~ 121) 117 (105 ~ 129)	0.5
220 (198 ~ 242) 230 (207 ~ 253) 240 (216 ~ 264)	0.3

### 3. APPLICATION EXAMPLES

#### 3-1. VOLTAGE MEASUREMENT

For voltage measurement, calibrate the instrument at appropriate sensitivity (10 mV/DIV or 50 mV/DIV for example) by connecting the CAL terminal (5) to CHL (6) (or CHR (8)), setting the VERT GAIN switch (12) (or switch (14) for CHR) at 1/1, and adjusting the VAR control (13) (or control (15) for CHR). During the voltage measurement, never disturb the adjusted position of VAR control (13) (or control (15) for CHR).

##### o DC voltage Measurement

Set the INPUT COUPLING switch (10) (or switch (11) for CHR) in the DC    state and the VERT GAIN switch (12) (or switch (14) for CHR) in the GND position.

With the VERTICAL POSITIONING knob  $\updownarrow$  (16), align the base line trace with a certain graticule scale line (a line lower than the center if the measured voltage is positive or a line higher than the center if the measured voltage is negative).

Set the VERT GAIN switch (12) (or switch (14) for CHR) at an appropriate range, and determine the deflection distance of the trace on the graticule. The voltage of the measured signal is calculated as follows:

$$\text{Voltage (V)} = \frac{\text{Sensitivity (V/DIV)} \times \text{Deflection distance (DIV)}}{\text{Indicated value of VERT GAIN (12) (or (14) for CHR)}}$$

For example, when the sensitivity is calibrated at 10 mV/DIV and the deflection amplitude is 5 DIV and the VERT GAIN (12) (or (14) for CHR) is 1/1, the DC voltage of the measured signal is calculated as follows:

$$10 \text{ (mV/DIV)} \times 5 \text{ (DIV)} \div 1/1 = 50 \text{ (mV)}$$

782130

If the deflection is upward the voltage is positive and if it is downward the voltage is negative.

o AC Voltage Measurement

Set the INPUT COUPLING switch (10) (or switch (11) for CHR) in the AC □ state and the VERT GAIN switch (12) (or switch (14) for CHR) in the GND position.

Align the trace base line with the graticule center line with the VERTICAL POSITIONING knob  $\updownarrow$  (16), set the VERT GAIN switch (12) (or switch (14) for CHR) at an appropriate range, and determine the deflection amplitude of the waveform on the graticule. The voltage is calculated as follows:

$$\text{Voltage (V)} = \frac{\text{Sensitivity (V/DIV)} \times \text{Deflection amplitude (DIV)}}{\text{Indicated value of VERT GAIN (12) (or (14) for CHR)}}$$

For example, when the sensitivity is calibrated at 10 mV/DIV and the deflection amplitude is 5 DIV and the VERT GAIN (12) (or (14) for CHR) is 1/1, the voltage is calculated as follows:

$$10 \text{ (mV/DIV)} \times 5 \text{ (DIV)} \div 1/1 = 50 \text{ (mVp-p)}$$

To compare the signal amplitude levels of CHL and CHR, set the sweep at a low frequency and determine the CHL deflection amplitude A (DIV) and CHR deflection amplitude B (DIV). (See Fig. 1.) The amplitude level difference (dB) is calculated as follows:

$$\text{Amplitude level difference (dB)} = 20 \text{ LOG } \frac{B}{A}$$



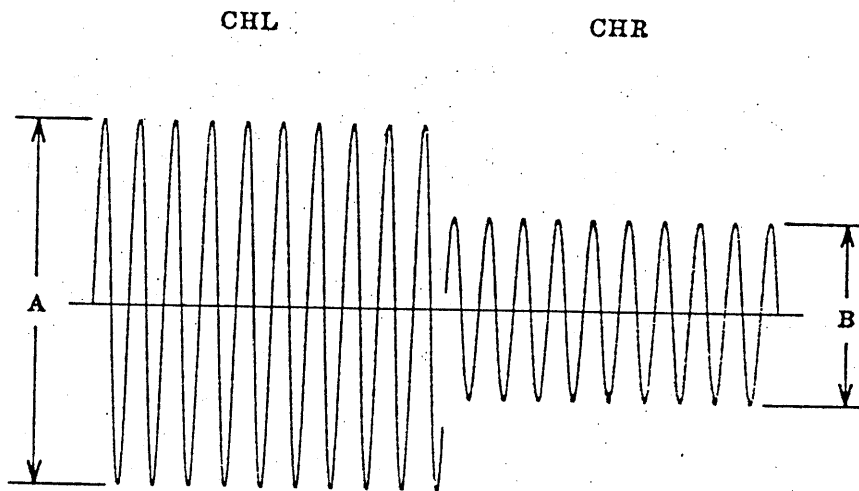

Fig. 1

### 3-2. FREQUENCY MEASUREMENT

#### o Frequency Measurement by Comparing Two Signals

Apply a known frequency signal (the output of a signal generator) and an unknown signal (the signal to be measured) to the CHL and CHR VERT INPUT terminals (6) and (8) -- either signal to either terminal and set the TRIGGER MODE switch (24) in the NORM     state. In this case the sweeps are synchronized with the input signals even if their frequencies are mutually different. Measurement can also be done by setting the DISPLAY MODE switch (18) in the V     state.

So vary the signal generator frequency that the periods of the displayed waveforms of CHL and CHR becomes equal, that is, the unknown frequency becomes the same with the known frequency.

Keeping the signal generator at a certain frequency ( $f$ ) and denoting by  $X$  (DIV) the horizontal length of one cycle of the generator signal and by  $X'$  (DIV) that of the unknown signal, the frequency of the unknown signal is calculated as follows:

782132

$$\text{Unknown frequency} = \frac{X}{X'} \times f$$

Using factor N which denotes the number of cycles of the higher frequency signal present in the same span of one cycle of the lower frequency signal, the unknown frequency can be calculated as follows:

$$\text{Unknown frequency} = N \times f$$

Where,  $f$  is the signal generator frequency which is lower than the measured signal frequency. (See Fig. 2.)

$$\text{Unknown frequency} = \frac{1}{N} \times f$$

Where,  $f$  is the signal generator frequency which is higher than the measured signal frequency. (See Fig. 2.)

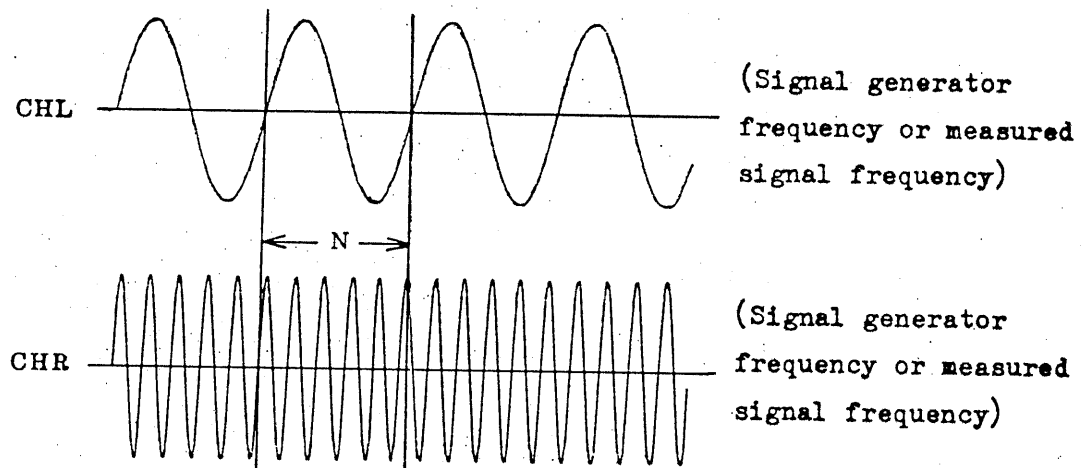

Fig. 2

782133

o Frequency Measurement with Lissajous Figures

Set the SWEEP RANGE switch (20) in the "X-Y" position, apply a known frequency signal (the output of a signal generator) to the CHL VERT INPUT terminal (6) and an unknown frequency signal (the signal to be measured) to the VERT INPUT terminal (8), and so adjust the sensitivities that the displayed signals deflect with the same amplitudes in X and Y directions.

Gradually vary the signal generator frequency to a point where the displayed pattern (Lissajous figure) becomes stationary. If the figure is a circle or a straight line there is a relationship of 1 : 1 ratio between the two frequencies or they are equal. When the figure has become stationary, there is an integer ratio relationship between the two frequencies enabling the unknown frequency to be calculated referring to the known frequency.

Typical Lissajous figures and frequency ratios of the two signals (X and Y). When the figures are as inverted by 90 degrees of phase angle, the ratios between the two signals are as inverted.

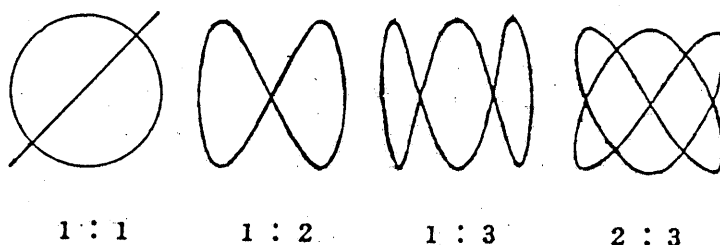

Fig. 3

### 3-3. PHASE MEASUREMENT

#### o Phase Measurement with Dual-channel Operation (1)

Set the TRIGGER MODE switch (24) in the CHL state. Apply to the CHL VERT INPUT terminal (6) the signal to be used as reference and to the CHR VERT INPUT terminal (8) the signal to be measured. Adjust the displayed signals of CHL and CHR to the same amplitude with the VERT GAIN switches (12) and (14) and VAR controls (13) and (15). Align the vertical positions of the two signals with the POSI BAL control (17). Determine the vertical distances A (DIV) and B (DIV) between reference signal and measured signal as shown in Fig. 4. The phase difference  $\alpha$  between the two signals is calculated as follows:

$$\alpha (^{\circ}) = \frac{B}{A} \times (\pm 180^{\circ})$$

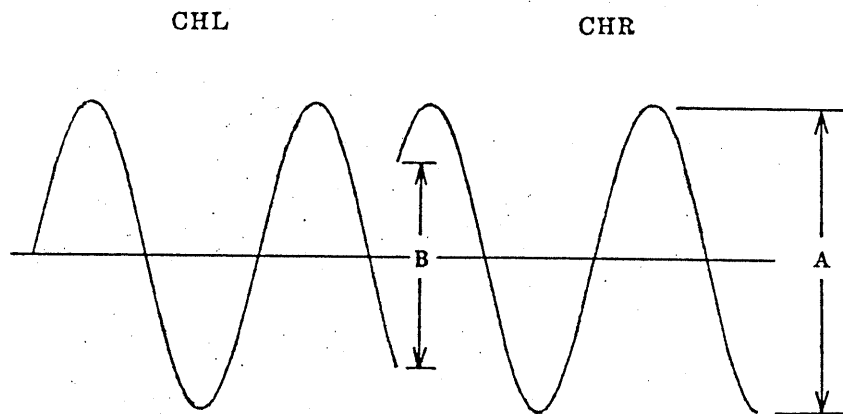

Fig. 4

782135

o Phase Measurement with Dual-channel Operation (2)

Set the TRIGGER MODE switch (24) in the CHL  state. Apply to the CHL VERT INPUT terminal (6) the signal to be used as reference and to the CHR VERT INPUT terminal (8) the signal to be measured. Determine the horizontal distances from the point where the CHL and CHR signals contact by falling on the same vertical line to the points where the signals crosses the horizontal base line as shown in Fig. 5. Denoting the distances by A (DIV) and B (DIV) and the signal period by T (DIV) as shown in Fig. 4, the phase difference  $\alpha$  is calculated as follows:

$$\alpha (^{\circ}) = \frac{A - B}{T} \times 360^{\circ}$$

The condition of  $A < B$  is for leading phase,  $A > B$  for lagging phase, and  $A = B$  for in phase.

For the above measurement, the displayed waveform amplitude of CHL and CHR signals need not be made equal. The only requirement is that they should be sufficient for measurement.

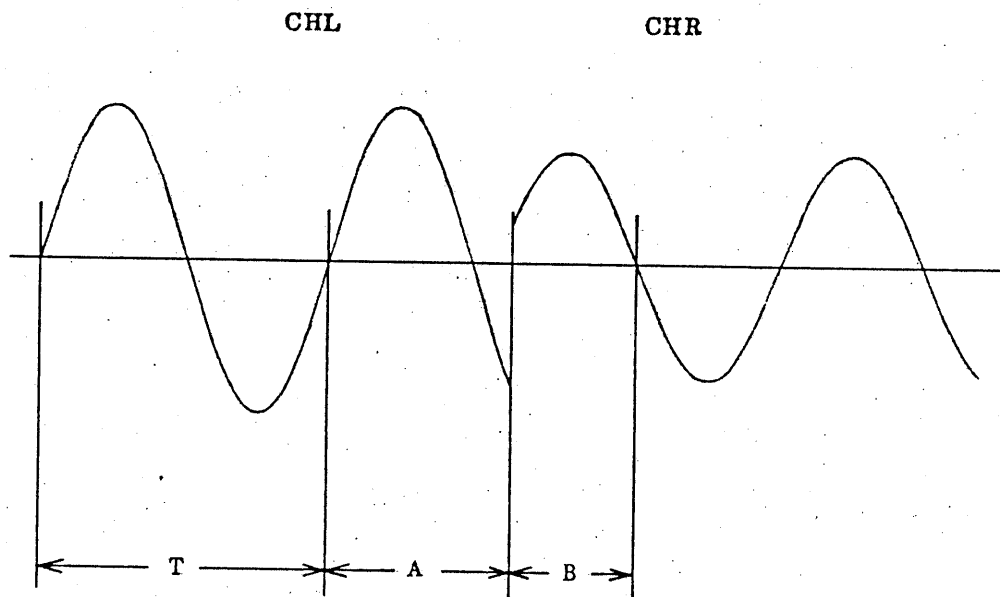

Fig. 5

782136

o Phase Measurement with Dual-channel Operation (3)

Set the TRIGGER MODE switch (24) in the CHL H state, apply to the CHL VERT INPUT terminal (6) the signal to be used as reference and to the CHR VERT INPUT terminal (8) the signal to be measured, and set the DISPLAY MODE switch (18) in the V m state. Measure the horizontal distance from the point where the reference signal (CHL) crosses the vertical-center line to the point where the measured signal (CHR) crosses the same line. Denoting the horizontal distance by A (DIV) and one cycle period by T (DIV), the phase difference  $\alpha$  is calculated as follows:

$$\alpha (^{\circ}) = \frac{A}{T} \times 360^{\circ}$$

If the crossing point of the measured signal (CHR) is leftward than that of the reference signal (CHL), the measured signal is leading with respect to the reference signal, and vice versa.

For the above measurement the amplitudes of the two signals are not required to be adjusted equal, the only requirement being that they should be sufficient for accurate observation.

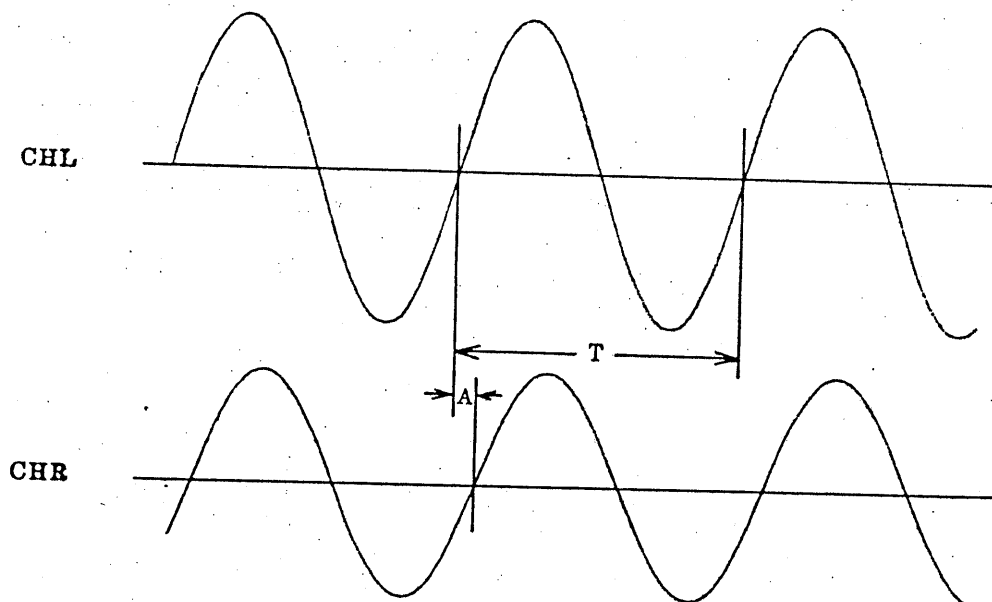

Fig. 6

o Phase Measurement with Lissajous Figure

Set the SWEEP RANGE switch (20) in the "X-Y" position, apply the input signals to the CHL and CHR VERT INPUT terminals (6) and (8), and adjust equal the X and Y amplitudes.

Denoting by A (DIV) the distance between the two points where the Lissajous figure crosses the X axis (or Y axis) and by B (DIV) the figure's amplitude in the X axis (or Y axis) with the figure positioned in the screen center as shown in Fig. 7, the phase difference  $\alpha$  is calculated as follows:

$$\sin \alpha = \frac{A}{B}$$

For example, when the amplitudes of both X and Y axes are 8 DIV, the phase difference is calculated referring to the distance between the two points where the figure crosses the X axis (or Y axis).

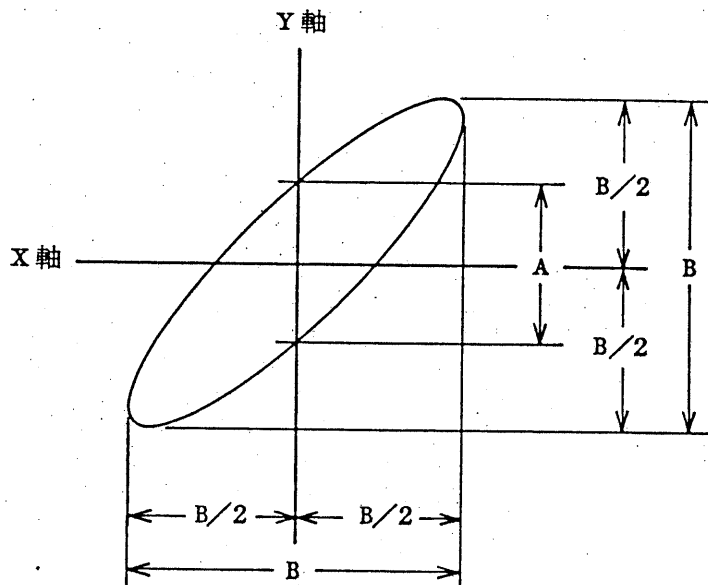

Fig. 7

782138

Table 1

Distance (DIV) on X or Y axis	Phase difference ( $^{\circ}$ )
0	0
0.1	0.7
0.2	1.4
0.3	2.2
0.4	2.9
0.5	3.6
1.0	7.2
1.5	10.8
2.0	14.5
2.5	18.2
3.0	22.0
3.5	25.9
4.0	30.0
5.0	38.7
6.0	48.6
7.0	61.0
8.0	90.0

The Lissajous figure is higher in the right-hand side when the phase difference is  $0^{\circ} \pm 90^{\circ}$  or it is higher in the left-hand side when the phase difference is  $180^{\circ} \pm 90^{\circ}$ . At  $90^{\circ}$  and  $270^{\circ}$ , the Lissajous figure is a circle.



#### 4. MAINTENANCE AND ADJUSTMENT

##### 4-1. MAINTENANCE

- o Removing the Casing (See Fig. 8)
  - (1) Remove the eight clamping-screws ( $M3 \times 6$ ) of the top and side panels of the casing, and remove the casing by pulling it upward holding it by its handle.
  - (2) Remove the bottom panel after removing its four clamping screws ( $M3 \times 6$ ).

Note: Before removing the casing, ensure that the POWER switch is turned OFF. Note that a high voltage of approximately 1400 V appears at the CRT tube socket and printed boards A2 and A3. Never touch these sections with your hand or a screwdriver after the casing is removed and the POWER switch is turned ON.

78211A0

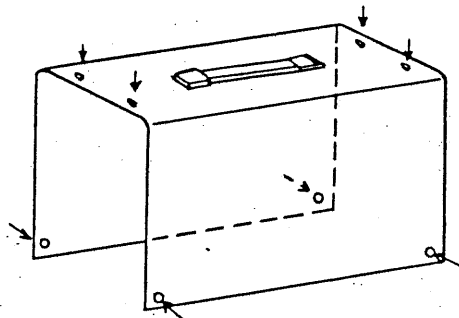

TOP SECTION  
OF CASING

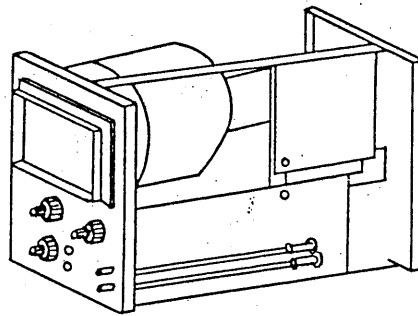

CHASSIS UNIT  
OF INSTRUMENT

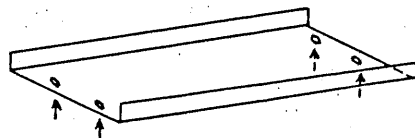

BOTTOM PANEL  
OF CASING

Fig. 8

o Adjustment of Horizontal Angle (Level) of Trace on CRT

- (1) Remove the top section of the casing and loosen the screw (M3 × 16) which tightens the bracket of the front end of the CRT.
- (2) So rotate the CRT that the trace line is made parallel with the graticule horizontal line. If the CRT rotation is heavy, loosen the clamping-screw of the shielding cylinder and slide backward the shielding cylinder.

782141

- (3) After making the trace line parallel with the horizontal line of the graticule, tighten the screws which have been loosened in (1) and (2) above. In this case, pay attention to that the trace line does not become slanted and that the shielding cylinder is fully pushed forward.

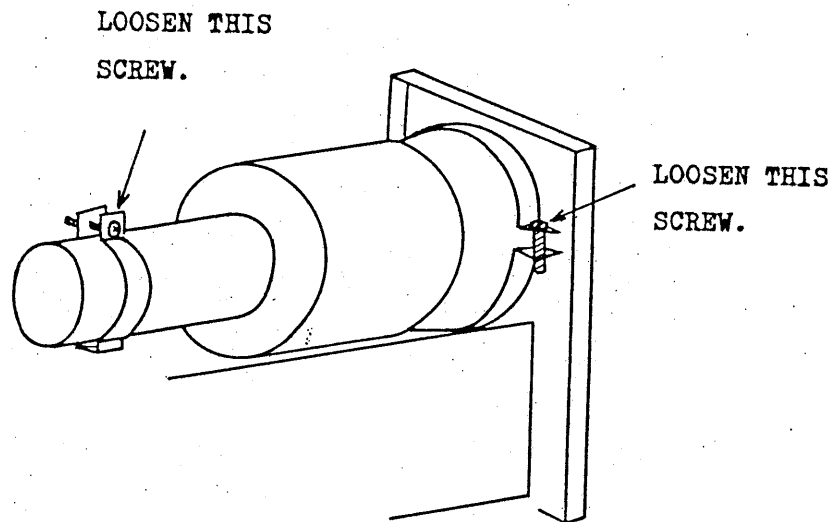

Fig. 9

#### 4-2. ADJUSTMENT

o Adjustment of DC BAL and POSI BAL  $\nabla$  (See Fig. 10)

- (1) Set the DISPLAY MODE switch (18) in the H  $\blacksquare$  state and the VERT GAIN switches (12) and (14) in the "GND" positions.
- (2) Set the VERT POSI knob  $\updownarrow$  (16) in the center position and the VAR knob (13) at the extremely counterclockwise position.
- (3) Turn the VAR knob (13) to the extremely clockwise position and, if the trace shifts as a result of this, so adjust the CHL DC BAL control (R1010) on the left-hand printed board that the trace is brought back to the original position.

782142

- (4) Repeat the procedures of (2) and (3) until the trace does not shift when the VAR knob (13) is turned.
- (5) Turn the VAR knob (15) to the extremely counterclockwise position. Align the CHR base line to the CHL base line by adjusting the POSI BAL control  $\blacktriangledown$  (17).
- (6) Turn the VAR knob (15) to the extremely clockwise position and, if the trace is shifted in this case, bring the trace to the original position by adjusting the CHR DC BAL control (R1060) on the left-hand printed board.
- (7) Repeat the procedures of (5) and (6) until the trace does not shift when the VAR knob (15) is turned.

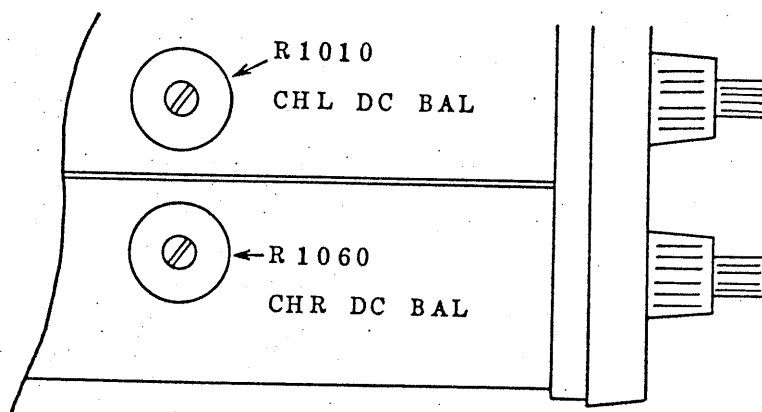

Fig. 10

782143

o Adjustment of Vertical Attenuator (See Fig. 11)

- (1) Prepare a pulse generator which provides a square wave output of 20 mV - 10 V<sub>p-p</sub>, 1 kHz. Apply this output signal to the CHL and CHR VERT INPUT terminals (6) and (8).
- (2) Set the VERT GAIN switches (12) and (14) in the "1/10" position and the VAR knobs (13) and (15) in the extremely clockwise position. So adjust the pulse generator output that the displayed waveform amplitude becomes 4 DIV, and so adjust trimmer capacitors C1002 (CHL) and C1016 (CHR) on the left-hand printed board that the displayed waveform has no overshoots or sags.
- (3) Set the VERT GAIN switches (12) and (14) in the "1/100" position, and adjust trimmer capacitors C1003 (CHL) and C1017 (CHR) in the same manner as (2) above.

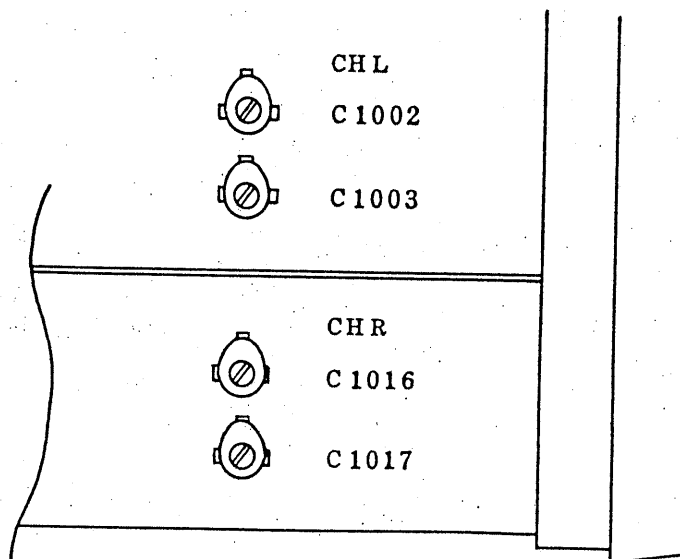

Fig. 11

o Adjustment of Distance Between Two Traces when in DISPLAY MODE  
V    Operation (See Fig. 12)

- (1) Set the VERT GAIN switches (12) and (14) in the "GND" position and the VAR knobs (13) and (15) at the extremely counterclockwise position.
- (2) Set the DISPLAY MODE switch (18) in the H    state, and align the CHL trace with the center line by adjusting the VERT POSI knob  $\updownarrow$  (16).
- (3) Align the CHR trace with the CHL trace by adjusting the POSI BAL control  $\blacktriangledown$  (17).
- (4) Set the DISPLAY MODE switch (18) in the V    state.
- (5) So adjust the V-POSI ADJ (R1027) on the left-hand printed board that the CHL trace is positioned 4 DIV upward with respect to the CHR trace.

o Adjustment of CAL Output Voltage (See Fig. 12)

- (1) Set the MODE switch (19) in the CHL state.
- (2) Set the VERT GAIN switch (12) in the "1/1" position, apply a 50 mV square wave to the CHL VERT INPUT terminal (6), and so adjust the VAR knob (13) that the displayed waveform amplitude becomes 5 DIV.
- (3) Connect the CAL terminal (5) to the CHL VERT INPUT terminal (6). So adjust the CAL ADJ (R1111) on the left-hand printed board that the displayed waveform amplitude becomes 5 DIV.

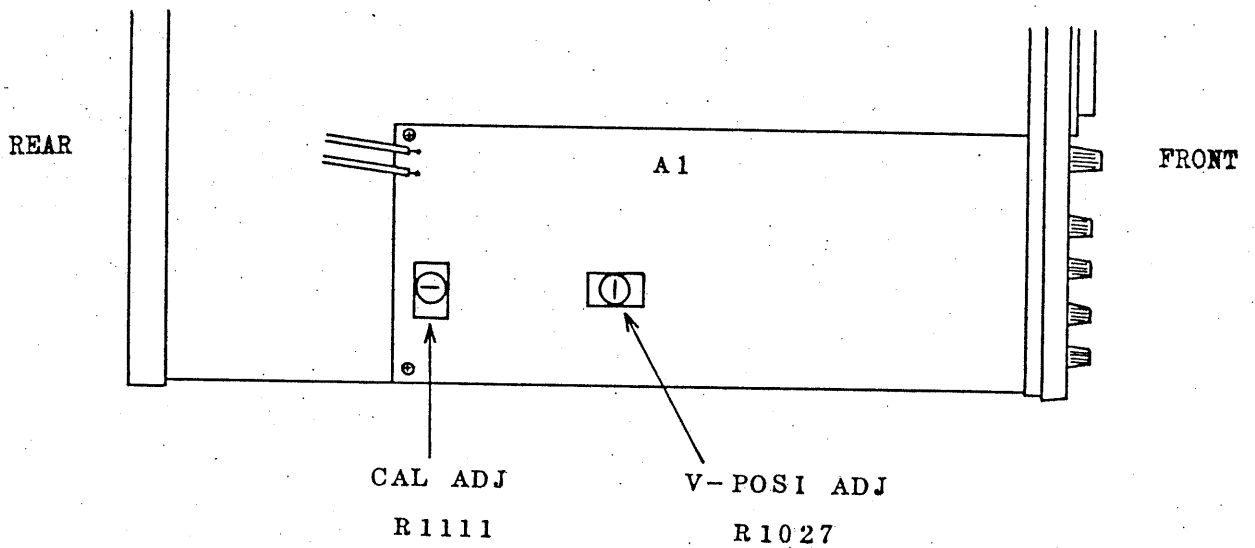

Fig. 12

o BAL Adjustment of CHL and CHR Trace Lengths (See Fig. 13)

- (1) Set the DISPLAY MODE switch (18) in the H II state, the SWEEP RANGE switch (20) in the "1k - 10k" position, and the VAR knob (21) in the extremely counterclockwise position.
- (2) Set the MODE switch (19) in the STEREO state. Move to the horizontal center of the CRT the average center position between CHL and CHR traces with the HORIZ POSI knob ↔ (23).
- (3) Adjust the CHL and CHR traces to the same length with the L/R BAL control (R2150) on the right-hand printed board. If the average center position is shifted from the CRT center, adjust it to the center with the HORIZ POSI knob ↔ (23).

78214

o Adjustment of Sweep Start Positions (▶◀ ADJ) (See Fig. 13)

- (1) Set the DISPLAY MODE switch (18) in the H  state, the SWEEP RANGE switch (20) in the "1k ~ 10k" range, and the VAR knob (21) at the extremely counterclockwise position.
- (2) Set the MODE switch (19) in the STEREO state.
- (3) So adjust the sweep start position control (▶◀ ADJ) (R2104) that the CHL and CHR traces starts at the two ends of the horizontal graticule line.

o Adjustment of Sweep Lengths (See Fig. 13)

- (1) Set the DISPLAY MODE switch (18) in the H  state, the SWEEP RANGE switch (20) in the "1k ~ 10k" range position, and the VAR knob (21) at the extremely counterclockwise position.
- (2) Set the MODE switch (19) in the STEREO state.
- (3) So adjust the sweep start position control (▶◀ ADJ) that the CHL and CHR sweeps start at the two ends of the horizontal graticule line.
- (4) So adjust the LENGTH ADJ (R2056) on the right-hand potentiometer that the CHL or CHR sweep length becomes 4.9 DIV. In this case the distance between the CHL and CHR traces at the CRT center should be about 0.2 DIV.
- (5) Check that the change in distance is within  $0.2 \pm 0.4$  DIV when the SWEEP RANGE switch (20) is turned or the VAR knob (21) is turned to the extremely clockwise or counterclockwise position.

782147



o Position Adjustment for X-Y Operation (See Fig. 13)

- (1) Set the DISPLAY MODE switch (18) in the H  state and the MODE switch (19) in the STEREO state.
- (2) Set the VERT GAIN switches (12) and (14) in the GND position.
- (3) Set the SWEEP RANGE switch (20) in the X-Y position and move the spot to the CRT screen center with the HORI POSI knob  $\leftrightarrow$  (23).
- (4) Set the SWEEP RANGE switch (20) in the "10 ~ 100" position.
- (5) Move the center of the distance between CHL and CHR traces to the CRT screen center by adjusting the POSI ADJ (R2111) on the right-hand printed board.

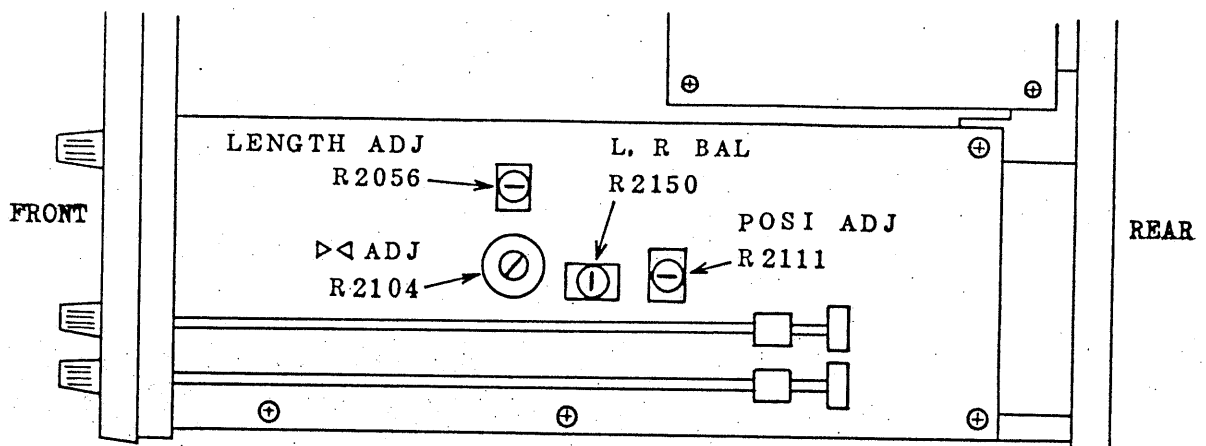

Fig. 13

782148

o Adjustment of Trigger DC BAL (See Fig. 14)

- (1) Set the TRIG LEVEL control (26) in its mid-position.
- (2) Set the VERT GAIN switches (12) and (14) in the "1/100" position and the VAR knobs (13) and (15) in the extremely clockwise position.
- (3) Set the SWEEP RANGE switch (20) in the "1k - 10k" position and the VAR knob (21) in the extremely counterclockwise position.
- (4) Set the TRIG switch (24) in the NORM    state and the switch (25) in the EXT    state.
- (5) Apply to the CHL and CHR VERT INPUT terminals (6) and (8) a sine wave signal of about 2 DIV and 1 kHz.
- (6) Apply the input signal of CHL or CHR to the EXT TRIG IN terminal (27), and so adjust the TRIG LEVEL control (26) that triggering is effected and the sweep is synchronized at the center of the displayed amplitude. Adjust again the TRIG LEVEL control (26) so that the sweep synchronization is maintained even when the input signal level is lowered.
- (7) Set the TRIG switch (25) in the INT    state, adjust the displayed signal amplitude at about 2 DIV, and so adjust the CHL DC LEVEL control (R1095) and CHR DC LEVEL control (R1106) on the left-hand printed board that the trigger point of CHL and CHR becomes the center of the displayed waveform. Also adjust so that the sweep synchronization is maintained even when the input signal level is lowered.

Note: When the TRIG switch (24) is changed from the CHL state to the NORM state, the trigger point of CHR is slightly shifted but it soon returns to the original point.

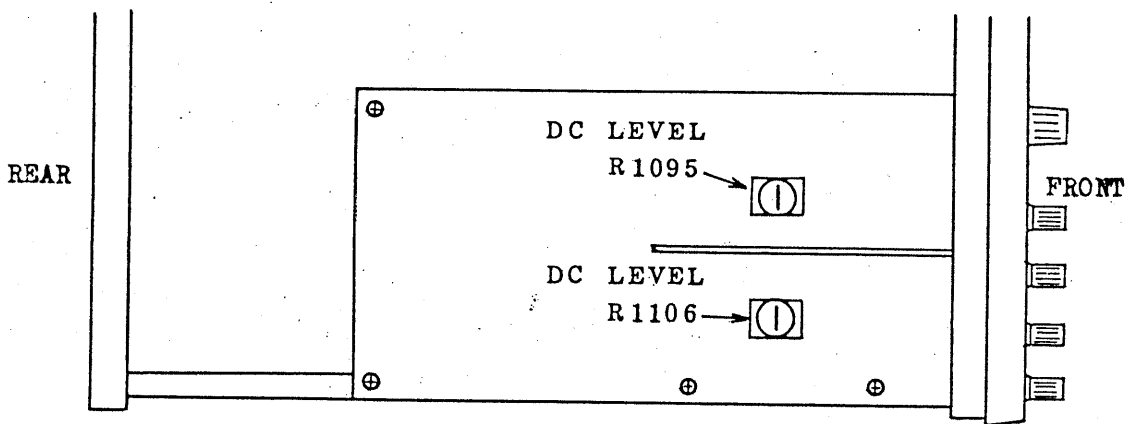

Fig. 14

o Adjustment of GEOM (See Figs. 15 and 17)

- (1) Set the VERT GAIN switches (12) and (14) in the "1/1" position and the VAR knobs (13) and (15) in the extremely clockwise position.
- (2) Set the SWEEP RANGE switch (20) in the X-Y position.
- (3) Set the INTEN knob (3) in a position slightly rightward than the center and the FOCUS knob (4) in the center.
- (4) Apply to the X-axis VERT INPUT terminal (6) a sine wave signal of approximately 8 kHz and to the Y-axis VERT INPUT terminal (8) a sine wave signal of approximately 10 kHz.

782150

- (5) So adjust the input signal amplitudes that the displayed raster amplitudes in the X and Y directions becomes approximately 8 DIV.
- (6) So adjust the GEOM control (R3041) on the right-hand printed board that the displayed raster area becomes square.

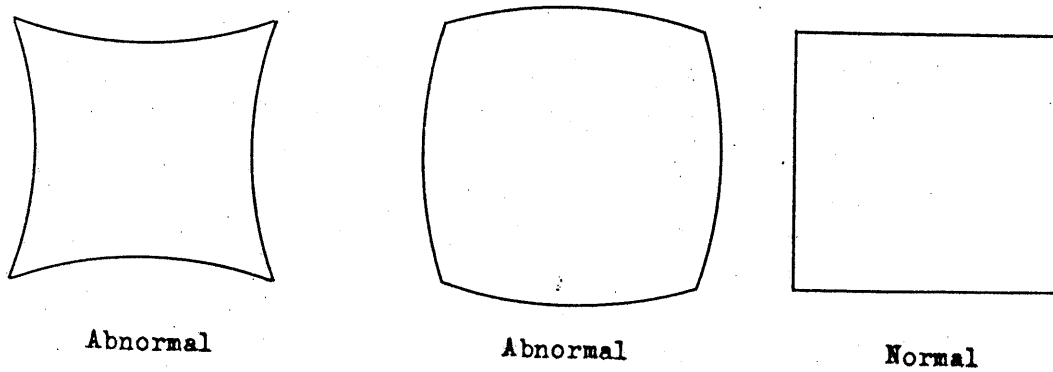

Fig. 15

o Adjustment of ASTIG (See Figs. 16 and 17)

- (1) Set the VERT GAIN switches (12) and (14) in the GND. position and set the spot in the CRT center by adjusting the VERT and HORIZ POSI knobs  $\updownarrow$  (16) and  $\leftrightarrow$  (23).
- (2) So adjust the ASTIG control (R3038) on the right-hand printed board and the FOCUS knob (4) on the front panel that the displayed spot becomes the smallest circle.

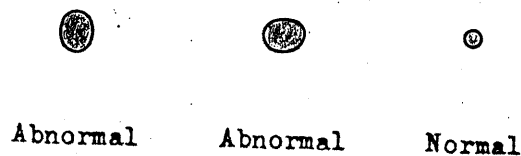

Fig. 16

782151

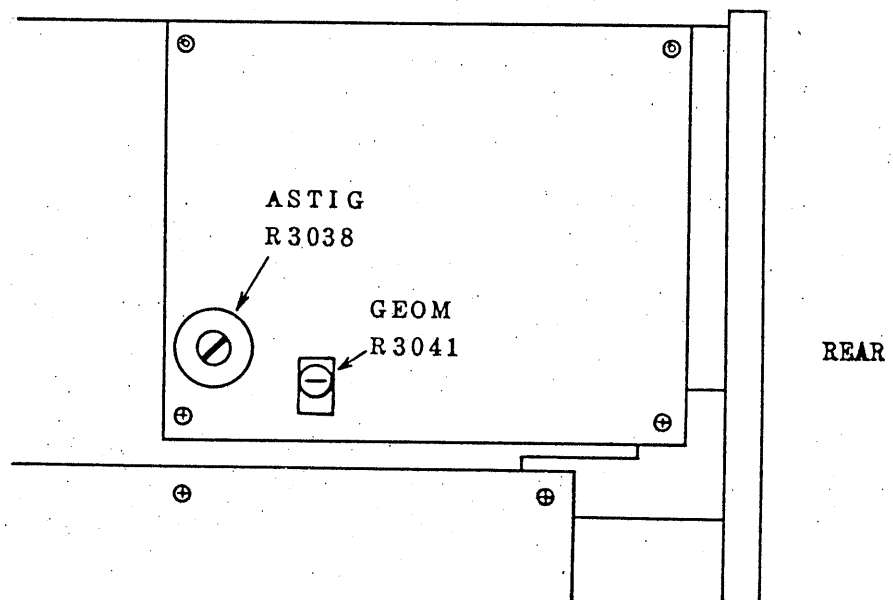
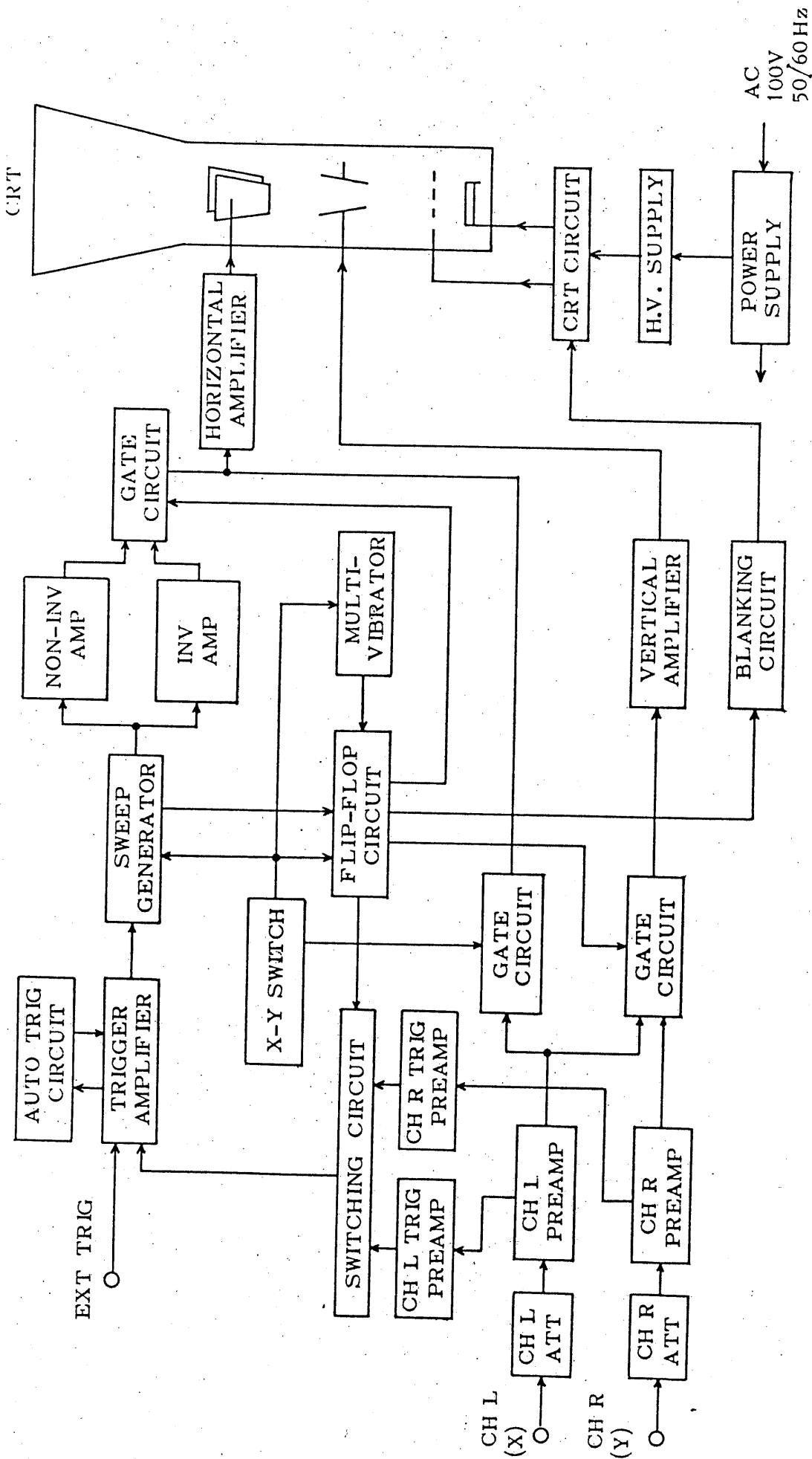

Fig. 17

782152



BLOCK DIAGRAM